

# Installation manual

## Tumble dryer

**DE-650S**  
**Compass Pro**  
Type N3...



**Electrolux**  
PROFESSIONAL

## **CONTACT:**

461 Doughty Blvd  
Inwood, NY 11096-0338  
Tel: 516-371-4400  
Fax: 516-371-4204  
Email: [sales@laundrylux.com](mailto:sales@laundrylux.com)

## **TECH SUPPORT:**

Tel: 516-371-0700  
Fax: 516-371-4029  
Email: [techcare@laundrylux.com](mailto:techcare@laundrylux.com)

## **PARTS:**

Tel: 516-371-2000  
Fax: 516-371-4029  
Email: [parts@laundrylux.com](mailto:parts@laundrylux.com)



# WARNING:

## **FIRE OR EXPLOSION HAZARD**

**Failure to follow safety warnings exactly could result in serious injury, death or property damage.**

**Do not store or use gasoline or other flammable vapors and liquids in the vicinity of this or any other appliance.**

## **WHAT TO DO IF YOU SMELL GAS:**

- **Do not try to light any appliance.**
- **Do not touch any electrical switch; do not use any phone in your building.**
- **Clear the room, building or area of all occupants.**
- **Immediately call your gas supplier from a neighbor's phone. Follow the gas supplier's instructions.**
- **If you cannot reach your gas supplier, call the fire department.**

**Installation and service must be performed by a qualified installer, service agency or the gas supplier.**

The above information; "What to do if you smell gas", shall be posted in a prominent location. The information to be posted shall be obtained by consulting with the local gas supplier.

# FOR YOUR SAFETY

**Do not store or use gasoline or other flammable vapors and liquids in the vicinity of this or any other appliance.**

The above information; "For your safety", shall be posted in a prominent location.

**MAKE CERTAIN TO KEEP THIS MANUAL IN A SECURE PLACE FOR FUTURE REFERENCE.**



# WARNING:

**This conversion kit shall be installed by a qualified service agency in accordance with the manufacturer's instructions and all applicable codes and requirements of the authority having jurisdiction. If the information in these instructions is not followed exactly, a fire, explosion or production of carbon monoxide may result causing property damage, personal injury or loss of life. The qualified service agency is responsible for the proper installation of this kit. The installation is not proper and complete until the operation of the converted appliance is checked as specified in the manufacturer's instructions supplied with the kit.**

**WARNING:** The dryer is intended for use only with fabrics that have been washed with water.

**WARNING:** To avoid fire hazard, do not dry articles containing foam rubber or similarly textured rubberlike materials.

**WARNING:** ALL OPERATING AND MAINTENANCE PROCEDURES SHOWN ON THE NEXT PAGE OF THIS MANUAL MUST BE FOLLOWED DAILY FOR PROPER OPERATION OF YOUR MACHINE.

Keep the dryer area clear and free from combustible materials, gasoline, and other flammable vapors and liquids.

The dryer must not be installed or stored in an area where it will be exposed to water and/or weather.

PLEASE ENTER THE FOLLOWING INFORMATION AS IT APPEARS ON THE MACHINE(S) DATA PLATE(S).

MACHINE TYPE OR MODEL	
MACHINE SERIAL NUMBER(S)	
ELECTRICAL CHARACTERISTICS: _____ VOLTS, _____ PHASE, _____ HZ.	

**Warning:** For your safety the information in this manual must be followed to minimize the risk of fire or explosion or to prevent property damage, personnel injury or death.

## **NOTICE TO: OWNERS, OPERATORS AND DEALERS**

IMPROPER INSTALLATION AND INADEQUATE MAINTENANCE, POOR HOUSEKEEPING AND WILLFUL NEGLIGENCE OR BYPASSING OF SAFETY DEVICES MAY RESULT IN SERIOUS ACCIDENTS OR INJURY. TO ASSURE THE SAFETY OF CUSTOMERS AND/OR OPERATORS OF YOUR MACHINE, THE FOLLOWING MAINTENANCE CHECKS MUST BE PERFORMED ON A DAILY BASIS.

1. **Prior to operation of the machine**, check to make certain that all operating instructions and warning signs are affixed to the machine and legible. Missing or illegible ones must be replaced immediately. Be sure you have spare signs and labels available at all times. These can be obtained from your dealer.
2. **Check the door safety interlock, as follows:**
  - a. OPEN THE DOOR of the machine and attempt to start in the normal manner:  
For coin-operated models, insert the proper coins to start the machine.  
For manually operated models, place the ON-OFF switch in the ON position and press the Start switch.

## **THE MACHINE(S) MUST NOT START !**

3. DO NOT UNDER ANY CIRCUMSTANCES ATTEMPT TO BYPASS OR REWIRE ANY OF THE MACHINE SAFETY DEVICES AS THIS CAN RESULT IN SERIOUS ACCIDENTS.
4. **Be sure to keep the machine(s) in proper working order:** Follow **all** maintenance and safety procedures. Further information regarding machine safety, service and parts can be obtained from your dealer.  
All requests for assistance must include the model, serial number and electrical characteristics as they appear on the machine identification plate. Insert this information in the space provided on the previous page of this manual.
5. **WARNING:** DO NOT OPERATE MACHINE(S) WITH SAFETY DEVICES BYPASSED, REWIRED OR INOPERATIVE! DO NOT OPEN MACHINE DOOR UNTIL DRUM HAS STOPPED ROTATING!

---

## NOTICE TO INSTALLER

Improper installation of this machine:

- May cause serious damage to the machine.
- May result in other property damage.
- May cause personal injury.
- Will void the manufacturer's warranty.

Connection to line Voltage or over-current protection devices other than those specified on the data plate may result in severe damage to machine components, and will void the manufacturer's warranty.

Refer to complete installation instructions provided in manuals accompanying the machine.

**Contact Electrolux Professional Technical Support with any questions BEFORE installing this machine. Damage resulting from inadequate installation materials or improper installation techniques will void the manufacturer's warranty.**

## Electrical Information

It is your responsibility to have **ALL** electrical connections (including grounding) made by a properly licensed and competent electrician to assure that the electrical installation is adequate and conforms with local and state regulations or codes.

In the absence of such codes, ALL electrical connections, material, and workmanship must **conform** to the applicable requirements of the NATIONAL ELECTRIC CODE ANSI/NFPA NO. 70 or the CANADIAN ELECTRICAL CODE, CSA C22.1 - both the latest edition.

The dryer, when installed, must be electrically grounded in accordance with local codes or, in the absence of local codes, with the National Electrical Code, ANSI/NFPA 70, or the Canadian Electrical Code, CSA C22.1. - both the latest edition.

**IMPORTANT:** Failure to comply with these codes or ordinances and/or the requirements stipulated in this manual can result in personal injury or component failure.

**NOTE:** Component failure due to improper installation will **VOID THE WARRANTY**.

**IMPORTANT:** A separate circuit serving each dryer must be provided. The dryer must be connected to copper wire only. **DO NOT** use aluminum wire which could cause a fire hazard.

**NOTE:** The use of aluminum wire will **VOID THE WARRANTY**

**CAUTION:** Label all wires prior to disconnection when servicing controls. Wiring errors can cause improper operation or component failure.

## Electrical Service

### Steam and gas dryers **ONLY**

**IMPORTANT:** The dryer must be connected to the electrical supply shown on the data label affixed to the dryer. In the case of 208 VAC or 240 VAC, the supply voltage **must match** the electric service specifications of the data label **exactly**. Wire **must be** properly sized to handle the rated current.

**WARNING:** 120 VAC, 208 VAC and 240 VAC ARE NOT THE SAME. Any damage done to dryer components due to improper voltage connections will **VOID THE WARRANTY**.



### Electric dryers **ONLY**

**IMPORTANT:** ALL electrically heated dryers must be connected to the electric supply service shown on the dryers data label which is affixed to the back side of the control (service) door. The connecting wires must be properly sized to handle the rated current.

**NOTE:** Component failure due to improper voltage application will **VOID THE WARRANTY**.

## Gas Information

It is your responsibility to have **ALL** plumbing connections made by a qualified professional to ensure that the installation is adequate and conforms with local and state regulations or codes. In the absence of such codes, **ALL** plumbing connections, material, and workmanship must conform with local codes or, in the absence of local codes, with the National Fuel Gas Code, ANSI Z223.1/NFPA 54, or the Natural Gas and Propane Installation Code, CSA B149.1; - both the latest edition.

On dryers not equipped with a gas union in the dryer manifold, the instructions shall specify that a listed connector in compliance with the **Standard for Connectors for Gas Appliances ANSI Z21.24 CSA 6.10**, be used to connect the dryer to the supply piping.

**IMPORTANT:** Failure to comply with these codes or ordinances, and/ or the requirements stipulated in this manual, can result in personal injury and improper operation of the dryer.

The dryer and its manually operated appliance main gas valve must be disconnected from the gas supply piping system during any pressure testing of that system at test pressures in excess of 1/2 psi (3.5 kPa). The dryer **must be** isolated from the gas supply piping system by closing its individual manual shut-off valve during any pressure testing of the gas supply piping system at test pressures equal to or greater than 1/2 psig (3.5 kPa).

**IMPORTANT:** Failure to isolate or disconnect the dryer from the gas supply as noted can cause irreparable damage to the gas valve and will **VOID THE WARRANTY**.

**WARNING:** **FIRES or EXPLOSION COULD RESULT.**



### Gas Supply

**NOTE:** Undersized gas piping will result in ignition problems, slow drying, increased use of energy, and can create a safety hazard.

The dryer **must be** connected to the type of heat/ gas indicated on the dryer data label. If this information does not agree with the type of gas available, **do not** operate the dryer, contact your local dealer.

**IMPORTANT:** Any burner changes or conversions must be made by a qualified licensed professional.

The input ratings shown on the dryer data label are for elevations of up to 1,999 feet. The adjustment or conversion of the dryer(s) in the field for elevations over 2,000 feet are made by changing each burner orifice. If these conversions are necessary, contact your local dealer.

## Natural Gas

If the pressure is too low, ignition failure and/or slow drying times may result. Excessively high supply pressure will result in erratic operation of the gas valves internal pressure regulator. Further information in section: Gas connection.

## Propane Gas

Dryers made for use with propane gas have the gas valve pressure regulator blocked open, so that the gas pressure **must be** regulated upstream of the dryer. In accordance with American Gas Association (AGA) standards, a gas pressure regulator, when installed indoors, must be equipped with a vent limiter or a vent line must be installed from the gas pressure regulator vent to the outdoors. The water column pressure **must be** regulated at the source (propane tank), or an external regulator must be added to each dryer. Further information in section: Gas connection.

## Piping/Connections

The dryer is provided with a 1/2" or a 3/4" N.P.T. inlet pipe connection extending out the rear area or through the top of the dryer. For ease of servicing, the gas supply line of each dryer should have its own shut-off valve.

The size of the gas supply line (header) will vary depending on the distance this supply line travels from the gas meter or, in the case of propane gas, the supply tank, the number of tees, other gas-operated appliances, etc. Specific information regarding supply line size should be determined by the gas supplier.

**NOTE:** Undersized gas supply piping can create a low or inconsistent gas pressure which will result in erratic operation of the burner ignition system.

Consistent gas pressure is essential at **ALL** gas connections. It is recommended that a 3/4- inch pipe gas loop be installed in the supply line serving the bank of dryers. An in-line pressure regulator **must be** installed in the gas supply line (header) if (natural) gas line pressure exceeds 12-inches water column pressure.

**IMPORTANT:** The information regarding the settings of the water column pressure for Natural gas dryers and Propane gas dryers is found in section: Gas connection. The pressure is required at the gas valve pressure tap of each dryer for proper and safe operation.

A 1/8" N.P.T. plugged tap, accessible for test gauge connection, **must be** installed in the main gas supply line immediately upstream of each dryer.

**IMPORTANT:** Pipe joint compounds that resist the action of natural gas and propane gas **MUST BE** used.

**WARNING:** Test **ALL** connections for leaks by brushing on a soapy water solution (liquid detergent also works well). **NEVER TEST FOR GAS LEAKS WITH AN OPEN FLAME.**

ALL components / materials **must conform** to NATIONAL FUEL GAS CODE specifications. It is important that gas pressure regulators meet applicable pressure requirements and that gas meters are rated for the total amount of appliance BTU's being supplied.

# Contents

---

## Contents

1	Safety Precautions .....	13
1.1	Additional safety precautions for gas heated tumble dryer .....	15
1.2	General safety information .....	15
1.3	Commercial use only .....	15
1.4	Copyright .....	15
1.5	Symbols .....	16
2	Warranty terms and exclusions .....	17
3	Technical data .....	18
3.1	Drawing .....	18
3.2	Technical data .....	19
4	Setup .....	20
4.1	General .....	20
4.2	Unpacking .....	20
4.3	Recycling instruction for packaging .....	21
4.4	Siting .....	22
4.5	Connection to network .....	23
4.6	Mechanical installation .....	23
	4.6.1 Securing the machine .....	24
	4.6.2 Connection branch .....	25
5	Evacuation system .....	26
5.1	Air principle .....	26
5.2	Fresh air .....	26
5.3	Exhaust duct .....	27
5.4	Shared exhaust duct .....	28
5.5	Exhaust dimensioning .....	28
5.6	Adjusting the air flow .....	29
6	Gas connection .....	32
6.1	General .....	32
6.2	Gas installation .....	33
6.3	Table of pressure and adjustment .....	34
6.4	Test run .....	35
6.5	Converting instructions .....	36
6.6	Data label .....	37
7	Electrical connection .....	38
7.1	Electrical installation .....	38
7.2	Single-phase connection .....	38
7.3	Three-phase connection .....	39
7.4	Electrical connections .....	41
8	At first power up .....	42
8.1	Select language .....	42
8.2	Set time and date .....	42
8.3	Activate/Deactivate the service alarm .....	42
9	Function check .....	43
10	Disposal information .....	45
10.1	Appliance recyclability and disposal .....	45
	10.1.1 Recyclability .....	45
	10.1.2 Procedure regarding appliance disposal and component / material recovery .....	45
10.2	Disposal of packing .....	45

The manufacturer reserves the right to make changes to design and component specifications.



## 1 Safety Precautions

- Servicing shall be carried out only by authorized personnel.
- Only authorized spare parts, accessories and consumables shall be used.
- The machine is not to be used if industrial chemicals have been used for cleaning.
- Do not dry unwashed items in the machine.
- **WARNING:** Items that have been soiled with substances such as hair care products, cooking oil, acetone, alcohol, petrol, kerosene, spot removers, turpentine, waxes and wax removers shall be cleaned sufficiently to remove the contaminant before being tumble dried. When washing such soiled items ensure the use of detergent as specified by the detergent manufacturer and select the highest suitable temperature. If in doubt, wash the items several times.
- Items such as foam rubber (latex foam), shower caps, waterproof textiles, rubber backed articles and clothes or pillows fitted with foam rubber pads should not be dried in the machine.
- Fabric softeners or similar products should be used as specified by the fabric softener instructions.
- The final part of a drying cycle occurs without heat (cool down cycle) to ensure that the items are left at a temperature that ensures that the items will not be damaged.
- Remove all objects from pockets such as lighters and matches.
- **WARNING.** Never stop the machine before the end of the drying cycle unless all items are quickly removed and spread out so that the heat is dissipated.
- Adequate ventilation has to be provided to avoid the back flow of gases into the room for appliances burning other fuels, including open fires.
- Exhaust air must not be discharged into a flue which is used for exhausting fumes from appliances burning gas or other fuels.
- The machine must not be installed behind a lockable door, a sliding door or a door with a hinge on the opposite side to that of the machine in such a way that a full opening of the machine is restricted.
- If the machine has a lint trap this has to be cleaned frequently.
- The lint must not be accumulated around the machine.
- **DO NOT MODIFY THIS APPLIANCE.**
- When performing service or replacing parts, the power must be disconnected.
- When the power is disconnected, the operator must see that the machine is disconnected (that the plug is removed and remains removed) from any point to which he has access. If this is not possible, due to the construction or installation of the machine, a disconnection with a locking system in the isolated position shall be provided.
- In accordance with the wiring rules: mount a multi-pole switch prior to the machine to facilitate installation and service operations.
- Stationary appliances not fitted with means for disconnection from the supply mains having a contact separation in all poles that provide full disconnection under overvoltage category III, means for disconnection must be incorporated in the fixed wiring in accordance with the wiring rules.
- **WARNING:** The appliance must not be supplied through an external switching device, such as a timer, or connected to a circuit that is regularly switched on and off by a utility.

- If different rated voltages or different rated frequencies (separated by a /) are stated at the machine data plate, instructions for adjusting the appliance for operation at the required rated voltage or rated frequency are stated in the installation manual.
- The openings in the base, shall not be obstructed by a carpet.
- Maximum mass of dry cloth: 2 x 23.5 kg / 2 x 51.8 lbs.
- A-weighted emission sound pressure level at working stations: 70 dB(A).

### 1.1 Additional safety precautions for gas heated tumble dryer

- Before installation, check that the local distribution conditions, nature of gas and pressure and the adjustment of the appliance are compatible.
- The machine is not to be installed in rooms containing cleaning machines with perchloroethylene, TRICHLOROETHYLENE or CHLOROFLUOROCONTAINING HYDROCARBONS as cleaning agents.
- NOTE: it is pointed out that the connection and commissioning of appliances complying with this standard are subject to observance of the installation regulations in force in the countries where these appliances are marketed.
- Connection to the appliance shall be made with a flexible hose suitable for the appliance category in accordance with national installation regulations of the country of destination and that in case of doubt the installer shall contact the supplier.
- The appliance should be installed on non-flammable materials for the floor, worktop and/or wall close to the appliance if required.
- If you can smell gas:
  - Do not switch on any equipment
  - Do not use electrical switches
  - Do not use telephones in the building
  - Evacuate the room, building or area
  - Contact the person responsible for the machine

### 1.2 General safety information

In order to prevent damage to the electronics (and other parts) that may occur as the result of condensation, the machine should be placed in room temperature for 24 hours before being used for the first time.





### 1.3 Commercial use only

The machine/machines covered by this manual is/are made for commercial and industrial use only.

### 1.4 Copyright

This manual is intended solely for consultation by the operator and can only be given to third parties with the permission of Electrolux Professional AB.

**1.5 Symbols**

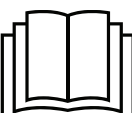
	Caution
	Caution, hot surface
	Caution, high voltage
	Warning, risk of fire / flammable material
	Danger, crush hazard
	Read the instructions before using the machine

## 2 Warranty terms and exclusions

If the purchase of this product includes warranty coverage, warranty is provided in line with local regulations and subject to the product being installed and used for the purposes as designed, and as described within the appropriate equipment documentation.

Warranty will be applicable where the customer has used only genuine spare parts and has performed maintenance in accordance with Electrolux Professional AB user and maintenance documentation made available in paper or electronic format.

Electrolux Professional AB strongly recommends using Electrolux Professional AB approved cleaning, rinse and descaling agents to obtain optimal results and maintain product efficiency over time.

The Electrolux Professional AB warranty does not cover:

- service trips cost to deliver and pick up the product;
- installation;
- training on how to use/operate;
- replacement (and/or supply) of wear and tear parts unless resulting from defects in materials or workmanship reported within one (1) week from the failure;
- correction of external wiring;
- correction of unauthorized repairs as well as any damages, failures and inefficiencies caused by and/or resulting from;
  - insufficient and/or abnormal capacity of the electrical systems (current/voltage/frequency, including spikes and/or outages);
  - inadequate or interrupted water supply, steam, air, gas (including impurities and/or other that does not comply with the technical requirements for each appliance);
  - plumbing parts, components or consumable cleaning products that are not approved by the manufacturer;
  - customer's negligence, misuse, abuse and/or non-compliance with the use and care instructions detailed within the appropriate equipment documentation;
  - improper or poor: installation, repair, maintenance (including tampering, modifications and repairs carried out by third parties not authorized third parties) and modification of safety systems;
  - Use of non-original components (e.g.: consumables, wear and tear, or spare parts);
  - environment conditions provoking thermal (e.g. overheating/freezing) or chemical (e.g. corrosion/oxidation) stress;
  - foreign objects placed in- or connected to- the product;
  - accidents or force majeure;
  - transportation and handling, including scratches, dents, chips, and/or other damage to the finish of the product, unless such damage results from defects in materials or workmanship and is reported within one (1) week of delivery unless otherwise agreed;
- product with original serial numbers that have been removed, altered or cannot be readily determined;
- replacement of light bulbs, filters or any consumable parts;
- any accessories and software not approved or specified by Electrolux Professional AB.

Warranty does not include scheduled maintenance activities (including the parts required for it) or the supply of cleaning agents unless specifically covered within any local agreement, subject to local terms and conditions.

Check on Electrolux Professional AB website the list of authorized customer care.

### 3 Technical data

#### 3.1 Drawing

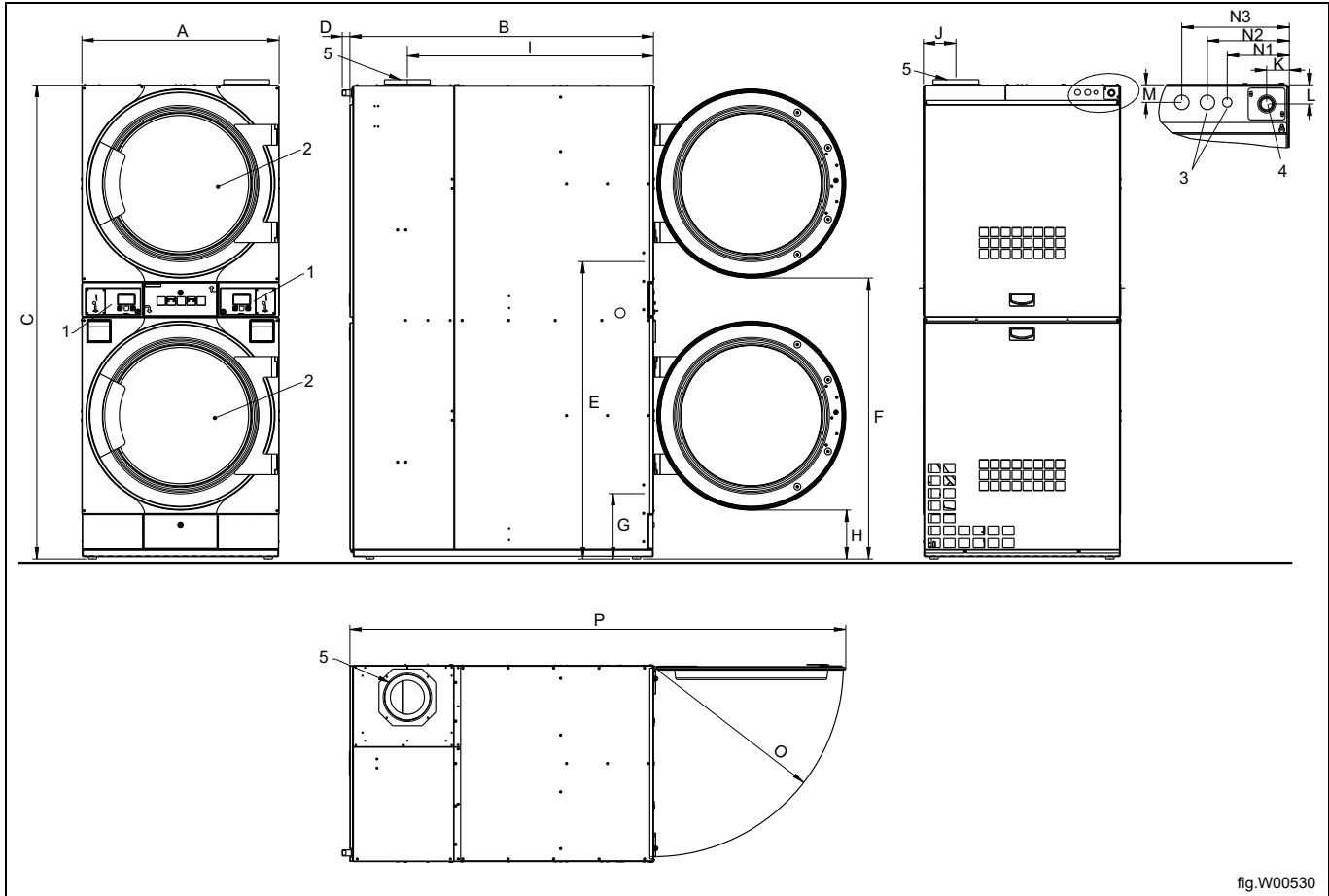

fig.W00530

1	Operating panel
2	Door opening, $\varnothing$ 687 mm / $\varnothing$ 27 1/16 inch
3	Electrical connection
4	Gas connection
5	Exhaust connection

	A	B	C	D	E	F
mm	870	1335	2085	35	1310	1240
inch	34 1/4	52 9/16	82 1/16	1 3/8	51 9/16	48 13/16

	G	H	I	J	K	L
mm	290	215	1085	140	40	35
inch	11 7/16	8 1/2	42 11/16	5 1/2	1 9/16	1 3/8

	M	N1	N2	N3	O	P
mm	30	110	145	190	815	2185
inch	1 3/16	4 5/16	5 11/16	7 1/2	32 1/16	86

### 3.2 Technical data

Weight, net	kg lbs	440 970
Drum volume	litres ft <sup>3</sup>	2 x 423 2 x 15
Drum diameter	mm inch	832 32 3/4
Drum depth	mm inch	757 29 13/16
Drum speed	rpm	43–44
Rated capacity, filling factor 1:18 (Max. load)	kg lbs	2 x 23.5 2 x 51.8
Rated capacity, filling factor 1:22 (Recommended load)	kg lbs	2 x 19.2 2 x 42.3
Heating: Gas	kW Btu/hr	2 x 27.5 94,000
Airborne sound level	dB(A)	70
Air flow	m <sup>3</sup> /h cubic feet per minute	2 x 850 2 x 500
Duct connection, exhaust	∅ mm ∅ inch	1 x 200 1 x 8
Maximum static back pressure, Gas 50 Hz / 60 Hz**	Pa WC	340 / 520 1.36 / 2.09
Gas pipe connection		3/4" MNPT
Sound power/pressure level at drying*	dB(A)	77/60
Heat emission of installed power, max	%	15

\* Sound power levels measured according to ISO 60704.

\*\* Static back pressure value measured in NTC position of bottom pocket only, in cold empty machine and running a program with no heat on both pockets at the same time.

#### Note!

- The default gas appliances are built to run on natural gas (GNH) according to 2H or 2E (G20).
- The default gas appliance shall not be installed at an altitude above 610 m (2001 ft).
- To run on another gas type or/and an altitude above 610 m (2001 ft) gas converting must be done on the machine.
- The gas converting accessories for other gases at altitudes below 610 m (2001 ft) are in the accessory bag.
- The high altitude accessory kit for altitudes above 610 m (2001 ft) is not included.
- The high-altitude kit is available to order for natural gas 2E (G20) and propane 3P, for the kit no. please refer to the spare parts list.
- For LPG use gas qualities according to GPA Midstream Standard 2140-23.

## 4 Setup

### 4.1 General

The principle work flow to setup or install this machine is as follows:

1. Unpacking
2. Positioning/siting, levelling or/and securing the machine.
3. Correcting the fresh air/air intake's size, exhaust duct's size and pipe(s) connections in considering a stand-alone machine or sharing exhaust duct.
4. Electric connections, connect the power supply to the machine.
5. Air flow or static back pressure adjustments in a cold empty machine in considering a stand-alone machine or sharing exhaust duct.
6. Gas connection. (For gas heated machine).
7. Function check.
8. Option functions check.

More details are described in each part of this installation manual.

### 4.2 Unpacking

#### Note!

**Two persons are recommended for the unpacking.**

Remove the bolts between the machine and pallet.

Remove the bottom filter drawer. Remove the panels on both sides of the filter drawer. Remove the two bolts at the front.

Remove the lower rear panel and remove the bolts.

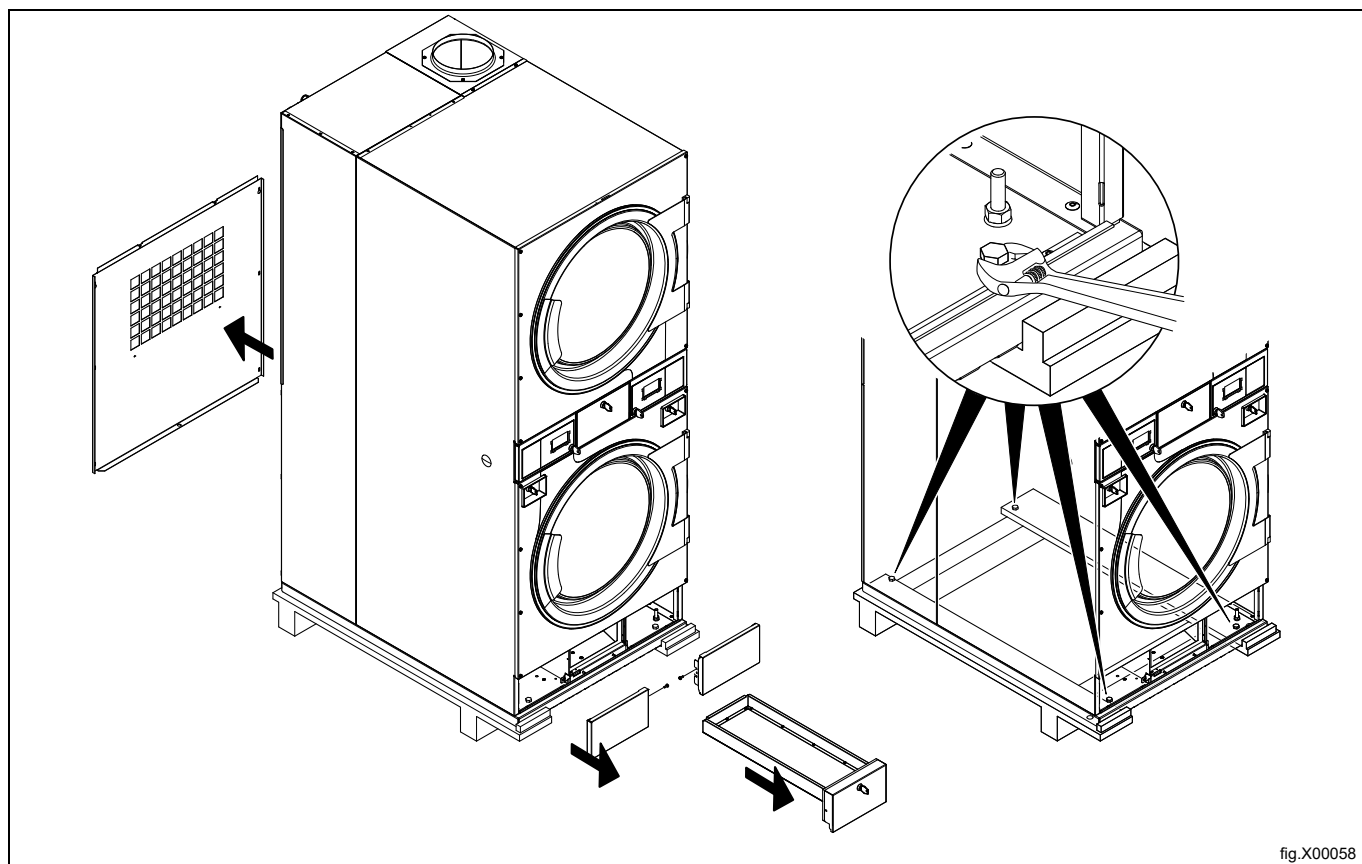

fig.X00058

Remove the machine from the pallet.

#### Note!

**When moving the machine, handle it with care. The drum has no transport clamps.**

Place the machine on its final position.

4.3 Recycling instruction for packaging

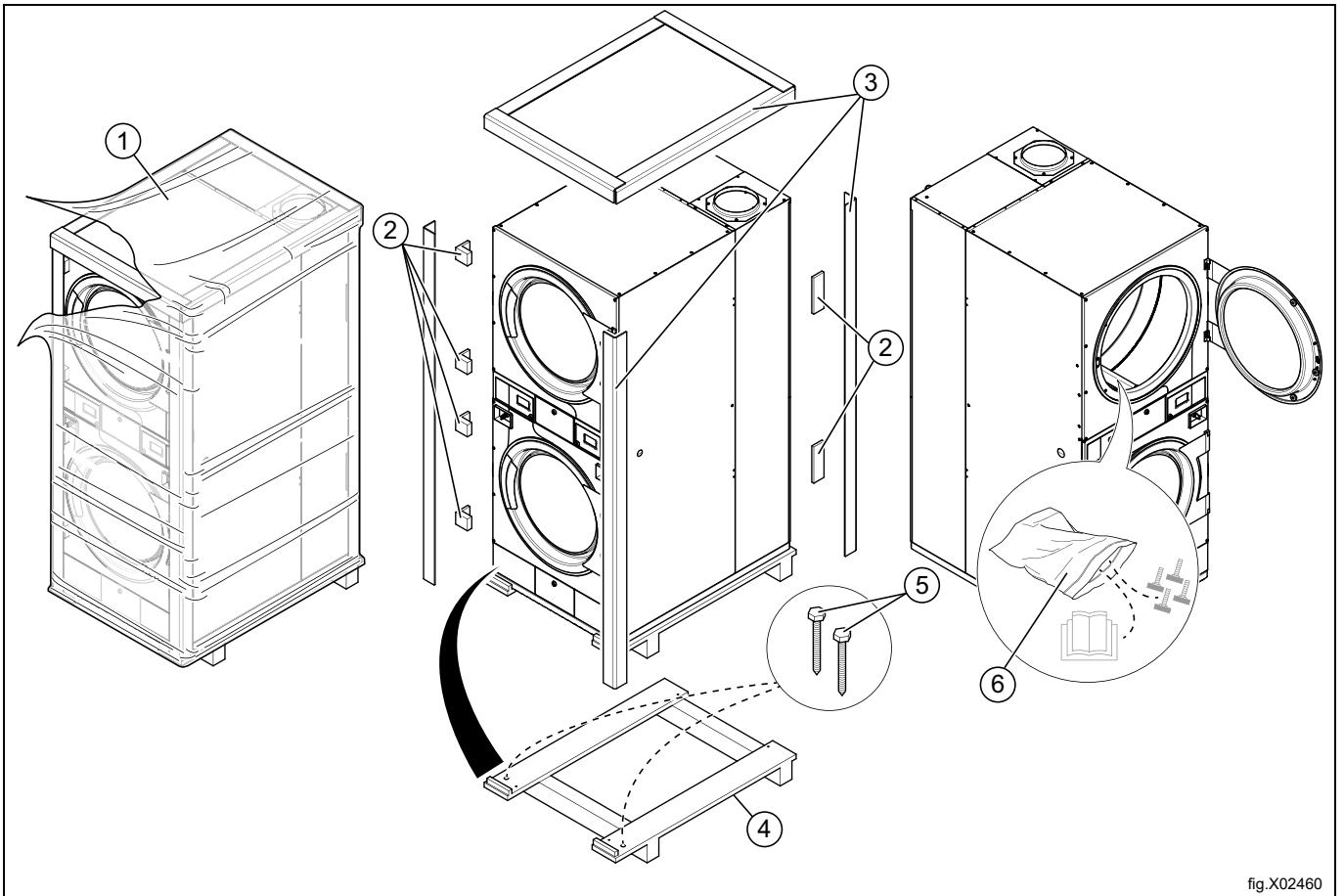

fig.X02460

Fig.	Description	Code	Type
1	Wrapping film	LDPE 4	Plastics
2	Corner protection	PS 6	Plastics
3	Cardboard packaging	PAP 20	Paper
4	Pallet	FOR 50	Wood
5	Screw	FE 40	Steel
6	Plastic bag	PET 1	Plastics

#### 4.4 Siting

The figure shows recommended distance to walls and/or other machines.

For the adequate clearance for air openings into the combustion chamber, clearances from combustible construction and adequate clearances for servicing and proper operation.

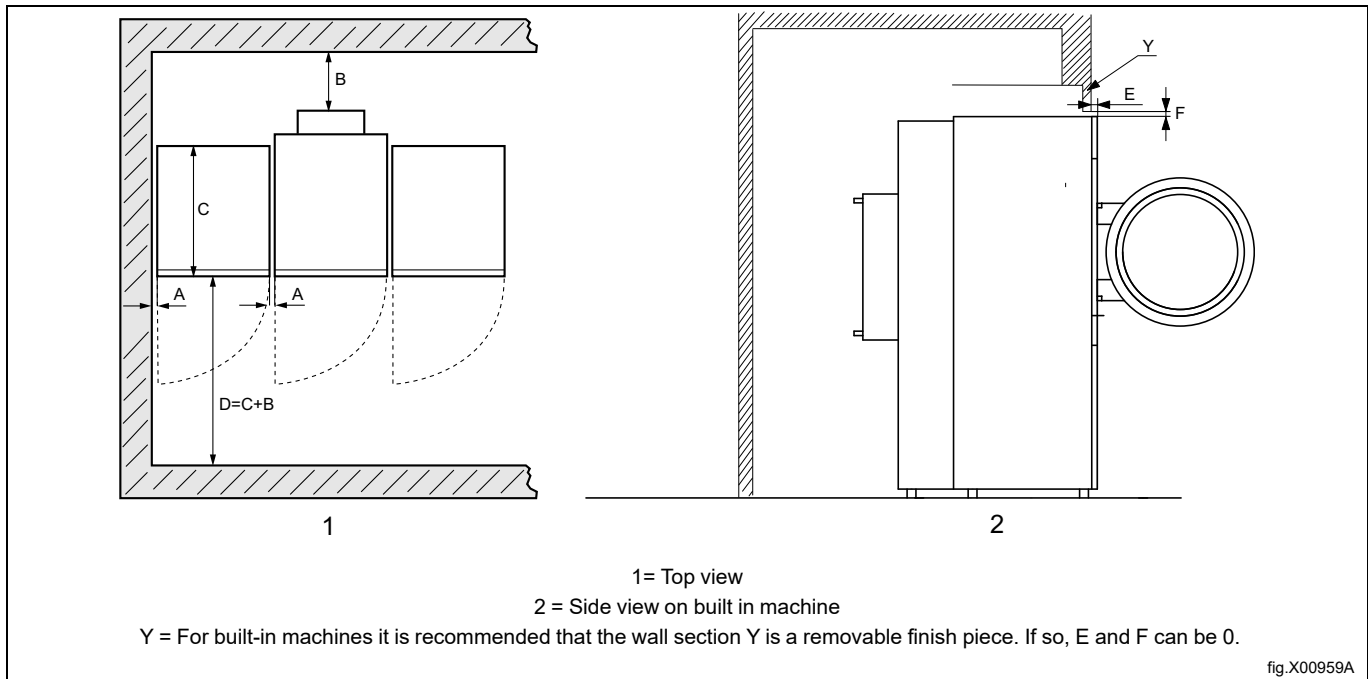

A	5–500 mm / 3/16–19 11/16 inch (Min. 0 mm / 0 inch, the units may be installed against one another)
B	500 mm / 19 11/16 inch (Min. 200 mm / 7 7/8 inch)
C	Depth of machine
D	$D = C + B$ (Min. 1220 mm / 48 inch to be able to use the machine)
E	Min. 20 mm / 13/16 inch
F	Min. 25.4 mm / 1 inch (The overhead soffit may be used to close the gap above the machine. Min. required clearance: 0 mm / 0 inch)

#### Note!

**The machine should be positioned so that there will be enough space for working, both for the user and service personnel.**

Respecting the given recommendations will provide easy access for maintenance and service operations.

In case of space limitations, it is possible to install machines without respecting to the given recommendations. If so, keep in mind that it might be necessary to disconnect and move other machines to be able to reach and perform service on affected machine.

### 4.5 Connection to network

If several machines are to be connected to a network, the knock-outs (A) in the side panels must be removed before installation.

A bushing for network cables must be installed from the inside in the right-hand side panel. The bushing must be pushed right through the hole in the left-hand side panel on the side of the machine.

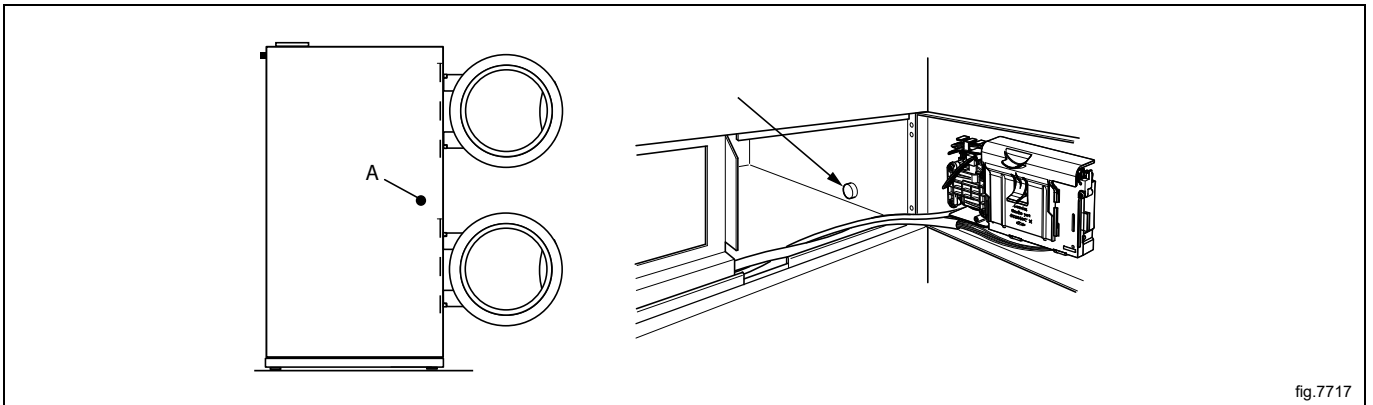

fig.7717

### 4.6 Mechanical installation

Level the machine with the feet of the machine. The maximum height adjustment of the feet is 15 mm / 9/16 inch.

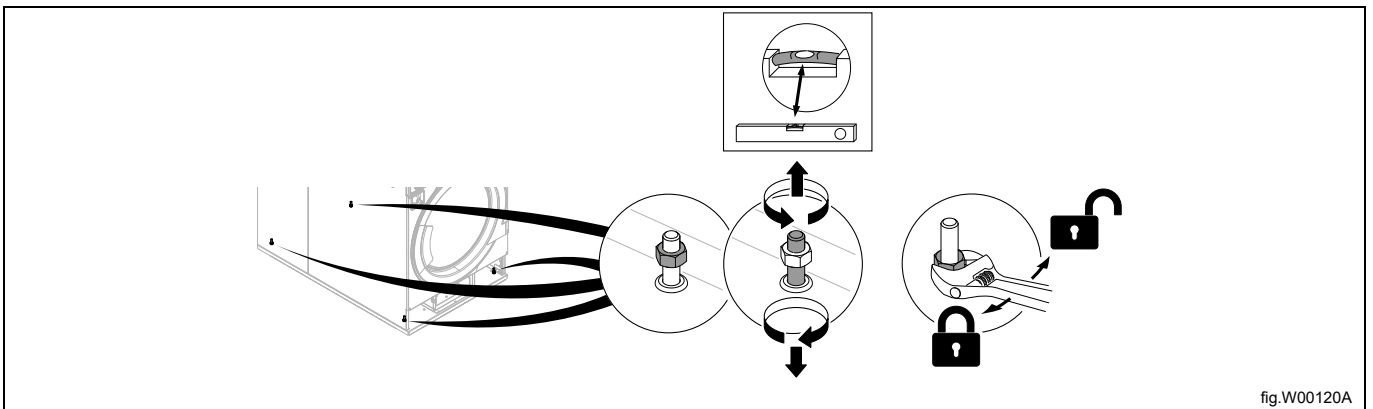

fig.W00120A

Remount the panels.

### 4.6.1 Securing the machine

To ensure steadiness of the machine it is important to fasten the machine to the foundation.

Fasten the four fittings (A) to the foundation using four x M10 set screws (B). If the four fittings are not supplied, order kit No. 487193544.

Fasten the machine to the fittings.

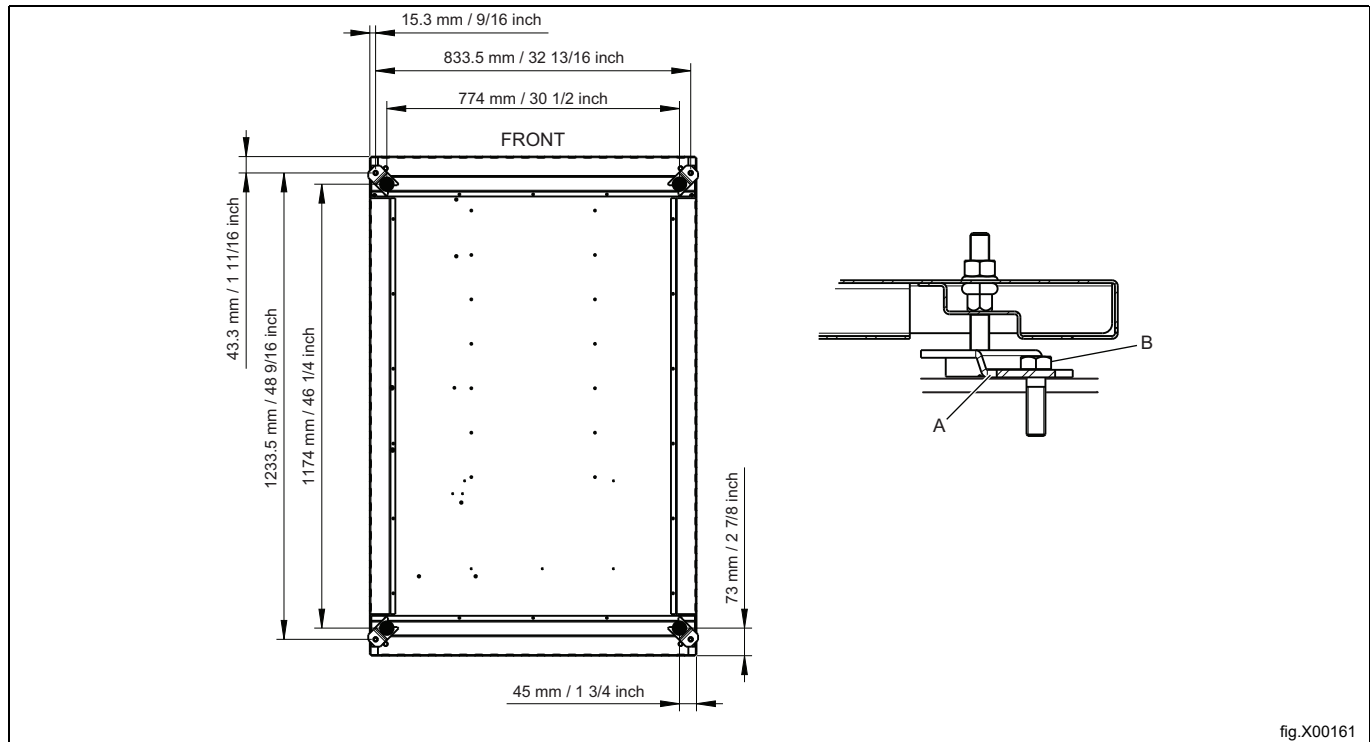

fig.X00161

**4.6.2 Connection branch**

Mount the enclosed branch at the top of the exhaust plenum with four screws.

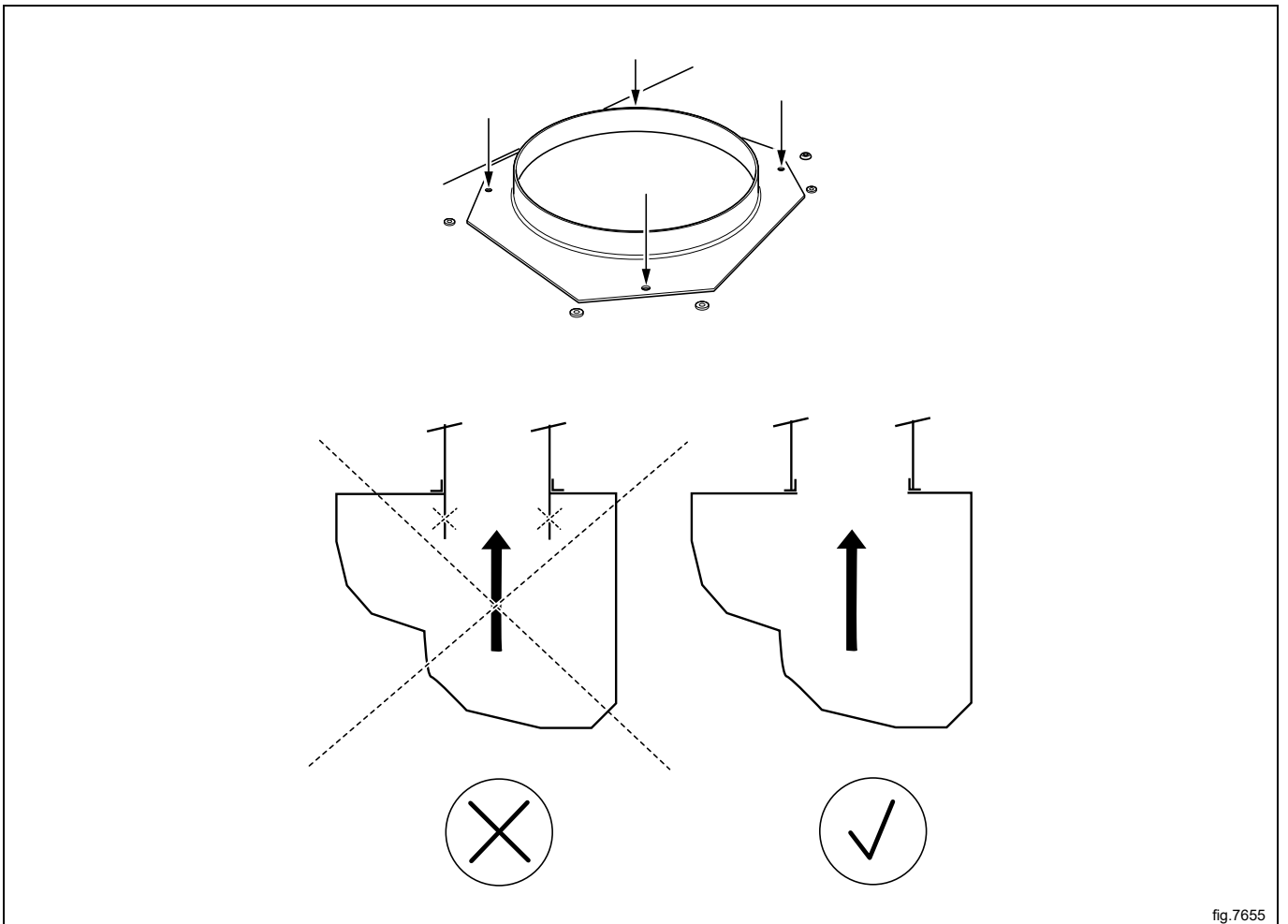

fig.7655

## 5 Evacuation system

### 5.1 Air principle

The fan creates low pressure in the machine, drawing air into the drum via the heating unit.

The heated air passes through the garments and the drum holes.

The air then flows out through a lint filter positioned below the drum. Then the air is evacuated through the fan and exhaust system.

#### **Note!**

**It is very important that the machine gets enough fresh air in order to get the best drying result.**

### 5.2 Fresh air

For maximum efficiency and the shortest possible drying time, it is important to ensure that fresh air is able to enter the room from the outside at the same time it is being exhausted by the machine.

To avoid creating a draught in the room it is important to place the make-up air inlet behind the machine.

Provisions for adequate air supply: The area of the air inlet opening should be 5 times the size of the exhaust pipe area to maximize efficiency. The minimum makeup air requirement for this product is 1.3 square feet (per dryer).

The area of the inlet opening is the area through which the air can flow without resistance from the grating/louver cover.

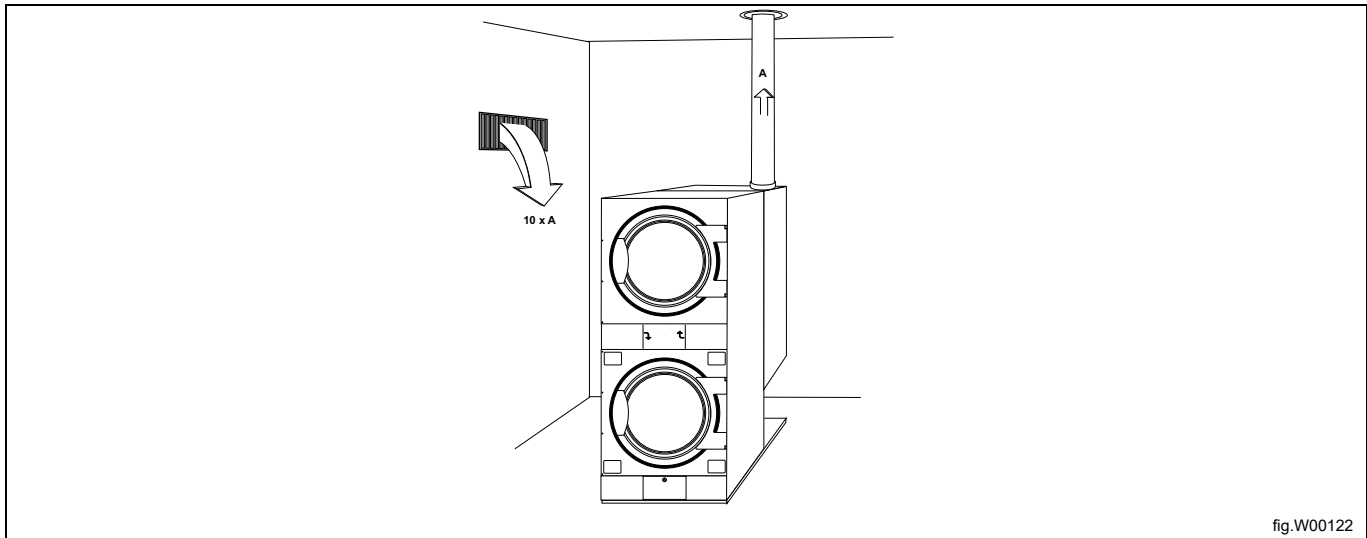

#### **Note!**

**Gratings/louver covers often block 1/3 of the total fresh air intake area. Remember to take this into account.**

#### **Note!**

**Make-up air must be free of dry cleaning solvent fumes.**

#### **Note!**

**Make-up air openings should not be located near to where the exhaust vents exit the building.**

### 5.3 Exhaust duct

- Only rigid or flexible metal duct should be used for exhausting.
- Plastic ducting is not to be used.
- Recommended material for exhaust is galvanized steel.
- The duct is not to be assembled with screws or other fastening means that extend into the duct and catch lint, instead use for example clamps and high temperature silicone.
- The exhaust air should not be vented into a wall, a ceiling, or a concealed space of building.
- The exhaust duct must lead clear of the building as condensation may cause frost damage to the building.
- The exhaust duct must lead to the outdoors.
- The exhaust duct must be placed in such a way that it is protected on the outside from for example impacts or water ingress.
- The exhaust duct must be smooth on the inside (low air resistance).
- The exhaust duct must have gentle bends.

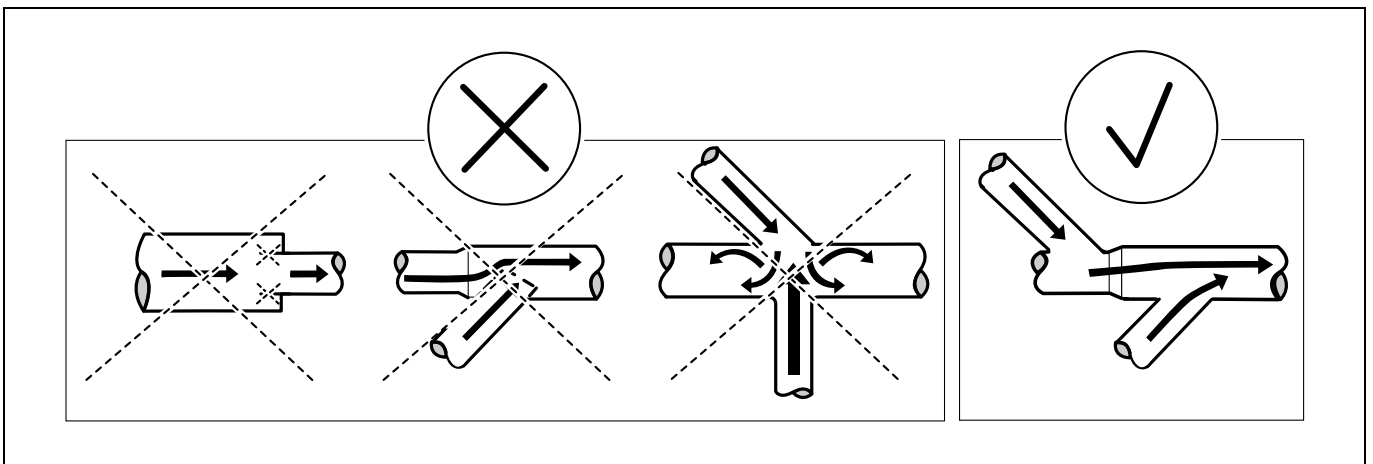

## 5.4 Shared exhaust duct



It is recommended that each machine is connected to a separate exhaust duct.



When several machines shall use the same exhaust duct the exhaust duct must increase before each machine is added. The individual ducts should enter the main duct at an angle of 45° or less and in the direction of airflow. The recommended diameter increase progression is the one in the table.

If there is more than one machine installed on the same exhaust pipe, it is mandatory to adjust the airflow/static back pressure on each machine when both pockets on all machines are started and running a program with no heat.

Please consider that unnecessarily large ducts create issues with the draught.

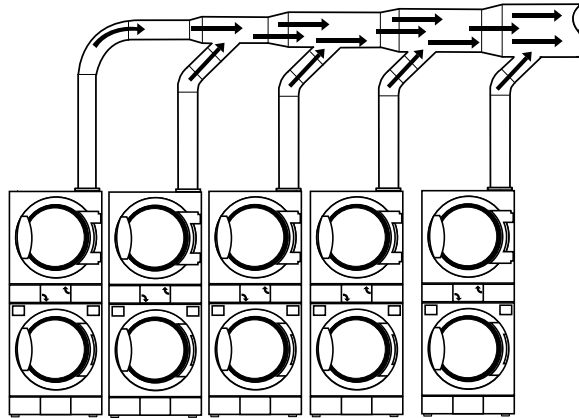

fig.W00123

Number of machines		1	2	3	4	5	6	7	8	9	10
Exhaust duct	ø mm	200	315	400	400	500	500	630	630	630	800
	ø inch	8	11	14	16	18	20	22	24	24	26
Recommended area of fresh air intake	m <sup>2</sup>	0.32	0.78	1.26	1.26	1.96	1.96	3.12	3.12	3.12	5.02
	ft <sup>2</sup>	3.44	6.68	10.76	14	17.66	21.74	26.48	31.44	31.44	36.8
Minimum area of fresh air intake	m <sup>2</sup>	0.16	0.32	0.48	0.64	0.8	0.96	1.12	1.28	1.44	1.6
	ft <sup>2</sup>	1.72	3.44	5.16	6.88	8.6	10.32	12.04	13.76	15.48	17.2



The exhaust duct diameter must not be reduced.



## 5.5 Exhaust dimensioning

It is important that the machine has correct air volume compared to each machines power.

If the air flow is smaller or larger this will result in a longer drying period.

If the outlet pipe is long or the ventilation is not properly designed we recommend to clean the outlet pipes periodically. Usually, longer ducts need more frequent cleaning.

The exhaust pipes shall be short in order for the machine to work in the best way.

All cover panels must be mounted in order for the machine to work in the best way.

## 5.6 Adjusting the air flow



Adjusting the air flow may only be carried out by authorized personnel.

For airflow adjustment ability, a damper need to be incorporated into the exhaust piping system.

An air reducing kit: 472997901 (damper) is available as an accessory to be ordered, or you can use a local resource damper.

If necessary, install the air reducing kit to the machine according to its instruction and then adjust the air flow/static back pressure according to the following instructions.

### Note!

**For stack dryer, the static back pressure value must be measured in NTC position of bottom pocket only, in a cold empty machine and running a program with NO heat on both pockets at the same time.**

### Note!

**Only on machines with 3-phase power supply, ensure that the direction of the fan wheel is correct. If the direction is wrong, swap two of the three phases on the connection terminal.**

- Demount the heating sensor (NTC sensor) (A) of the bottom pocket and insert the measuring device. Make sure the connection is tight to prevent air leakage.
- Connect the power to the machine according to "Electrical connection" section.
- Measure with a pressure measuring instrument (manometer), in cold empty machine and running a program with NO heat on both pockets at the same time.

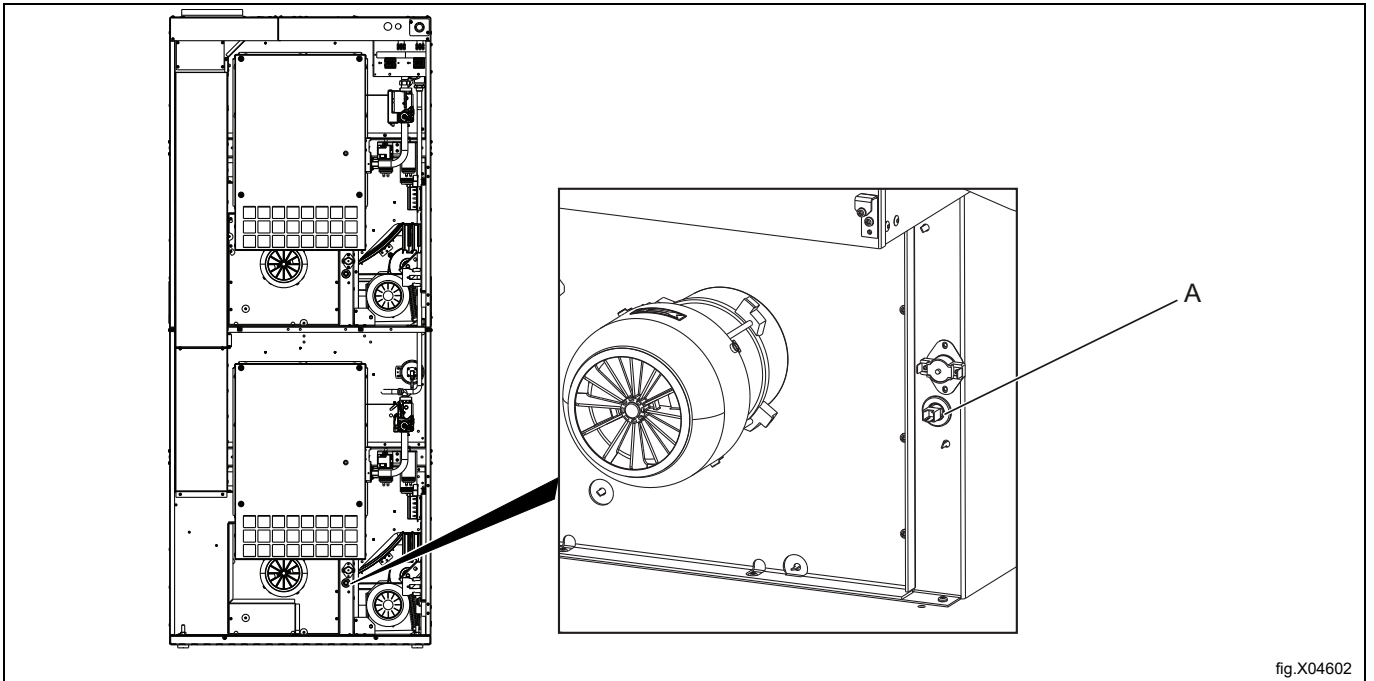
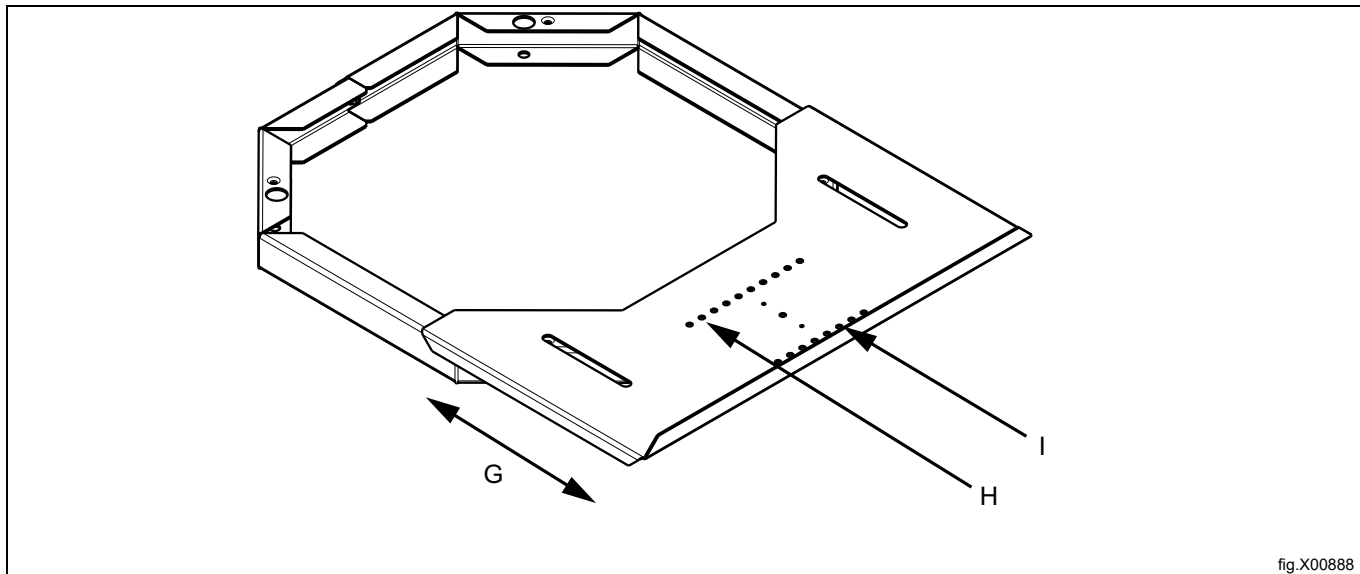

fig.X04602

If the air reducing kit: 472997901 has been installed, follow the example on how to adjust the air flow.

- Adjust the air flow/static back pressure according to provided technical data and tighten the screws completely when the correct air flow has been achieved.
- Slide the reducing plate (G) to adjust the air flow.
  - 100% open (H).
  - 80% open (I).



Heating / Frequency	Static back pressure value measured in NTC position of bottom pocket only, in cold empty machine and running a program with no heat on both pockets at a time (Pa)
Gas 50 Hz	340
Gas 60 Hz	520

**Alternative measuring method**



Adjusting the air flow may only be carried out by authorized personnel.

Use a home made U tube manometer, a hose (max  $\varnothing$  10 mm), with water. Insert one end of the hose in the hole, hold the hose according to the picture so that the water is in level.

Start the machine and measure the difference between the water in one of the hose ends with the other.

1 mm water column = 10 Pa.

1/16 inch water column = 0.0014 PSI

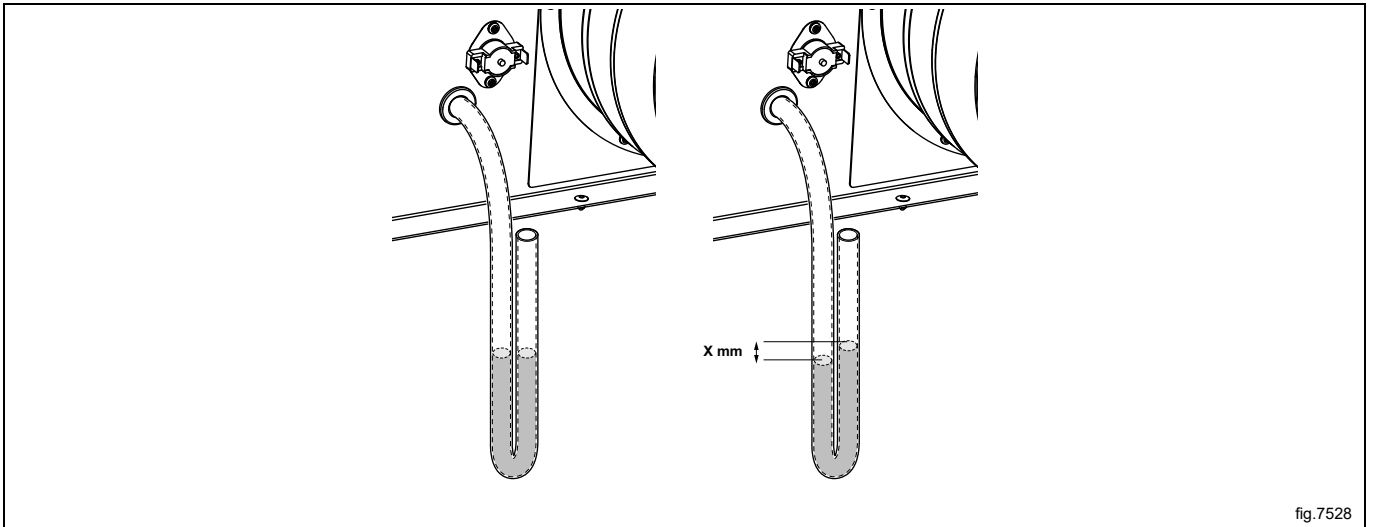

fig.7528

When the dryer is adjusted remount the heating sensor (NTC sensor) (A)

## 6 Gas connection

### 6.1 General



#### Caution



It is your responsibility to have all plumbing connections made by a qualified professional to insure that the gas plumbing installation is adequate and conforms with local and state regulations or codes. In the absence of such codes, ALL plumbing connections, material, and workmanship must conform to the applicable requirements of the National Fuel Gas Code ANSI Z223.1 LATEST EDITION or the CAN/CGA—B149, INSTALLATION CODES, both the latest edition.

Mount a shut-off valve upstream from the machine.

The gas connection to the machine should be dimensioned to an output depending upon the kW-rating of the machine.

The factory nozzle pressure setting must correspond to the fuel value given on the data label.

Check that the nozzle pressure and fuel value correspond with the values in the gas tables on the following pages. If not, contact the supplier.

Bleed the pipe system before connecting the machine.

#### Note!

**After connection all joints must be checked. There must not be any leaks.**

The machine and its individual shut-off valve must be disconnected from the gas supply piping system during any pressure testing of the system at test pressures in excess of 1/2 psi (3.5 kPa).

The machine must be isolated from the gas supply piping system by closing its individual manual shut-off valve during any pressure testing of the gas supply piping system at test pressures equal to or greater than 1/2 psi (3.5 kPa).

A minimum 1/8 inch N.P.T plugged tap, accessible for test gage connection, must be installed immediately upstream from the gas supply connections to the machine.

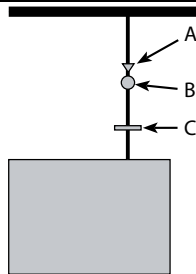

fig.7202

A = Pressure regulator (option) propane only

B = Gas shut-off valve

C = 1/8 inch N.P.T plugged tap

## 6.2 Gas installation

### Note!

- The default gas appliances are built to run on natural gas (GNH) according to 2H or 2E (G20).
- The default gas appliance shall not be installed at an altitude above 610 m (2001 ft).
- To run on another gas type or/and an altitude above 610 m (2001 ft) gas converting must be done on the machine.
- The gas converting accessories for other gases at altitudes below 610 m (2001 ft) are in the accessory bag.
- The high altitude accessory kit for altitudes above 610 m (2001 ft) is not included.
- The high-altitude kit is available to order for natural gas 2E (G20) and propane 3P, for the kit no. please refer to the spare parts list.
- For LPG use gas qualities according to GPA Midstream Standard 2140-23.

The data label shows the injector size and the injector pressure and the countries that use this gas quality:

AL	Albania	IE	Ireland
AT	Austria	IS	Iceland
BE	Belgium	IT	Italy
BG	Bulgaria	LT	Lithuania
CH	Switzerland	LU	Luxembourg
CY	Cyprus	LV	Latvia
CZ	Czech Republic	MK	Republic of Macedonia
DE	Germany	MT	Malta
DK	Denmark	NL	Netherlands
EE	Estonia	NO	Norway
ES	Spain	PL	Poland
FI	Finland	PT	Portugal
FR	France	RO	Romania
GB	United Kingdom	SE	Sweden
GR	Greece	SI	Slovenia
HR	Croatia	SK	Slovakia
HU	Hungary	TR	Turkey

You should check the kind of energy gas that is available in your place and check high altitude of the machine located place.

There are many gas types of the same kind but the machine should be equipped with different kinds of nozzles depending on the gas type.

For non-european countries check the heat value of the energy gas and compare it to the declared heat value of gas in the attached label.

### 6.3 Table of pressure and adjustment

Gas category	Heating power (BTH/h)	Inlet pressure (WC")	Nozzle pressure (WC")	Nozzle size (ø mm)	Air reducing/restriction plate (mm)	Label number
Natural	2 x 93900	7	3.2	4.60	No	Default
Propane HD-5 according to GPA Midstream Standard 2140-23	2 x 93900	11	11	2.80	No	490375747

#### Note!

- The default gas appliances are built to run on natural gas (GNH) according to 2H or 2E (G20).
- The default gas appliance shall not be installed at an altitude above 610 m (2001 ft).
- To run on another gas type or/and an altitude above 610 m (2001 ft) gas converting must be done on the machine.
- The gas converting accessories for other gases at altitudes below 610 m (2001 ft) are in the accessory bag.
- The high altitude accessory kit for altitudes above 610 m (2001 ft) is not included.
- The high-altitude kit is available to order for natural gas 2E (G20) and propane 3P, for the kit no. please refer to the spare parts list.
- For LPG use gas qualities according to GPA Midstream Standard 2140-23.

## 6.4 Test run

### Note!

Before test run the machine, ensure that the air flow/static back pressure has been adjusted accorded to the "Evacuation system" section. Adjust the air flow if necessary.

- Loosen the measuring branch screw (2) 1/4 turn; connect a manometer to the measuring branch and make sure the connection is tight to prevent air leakage.
- Connect the power to the machine and select a program with heat.
- Start the machine.
- Check that the nozzle pressure is correct according to the gas type, see "Table of pressure and adjustment".
- If the nozzle pressure should be adjusted:
  - Demount the cover screw (3).
  - Turn the screw (4). Clockwise: increasing nozzle pressure.
  - Turn the screw (4). Counter Clockwise: decreasing nozzle pressure.
- Check that the gas is burning evenly. The blue flame on the burner is preferred.

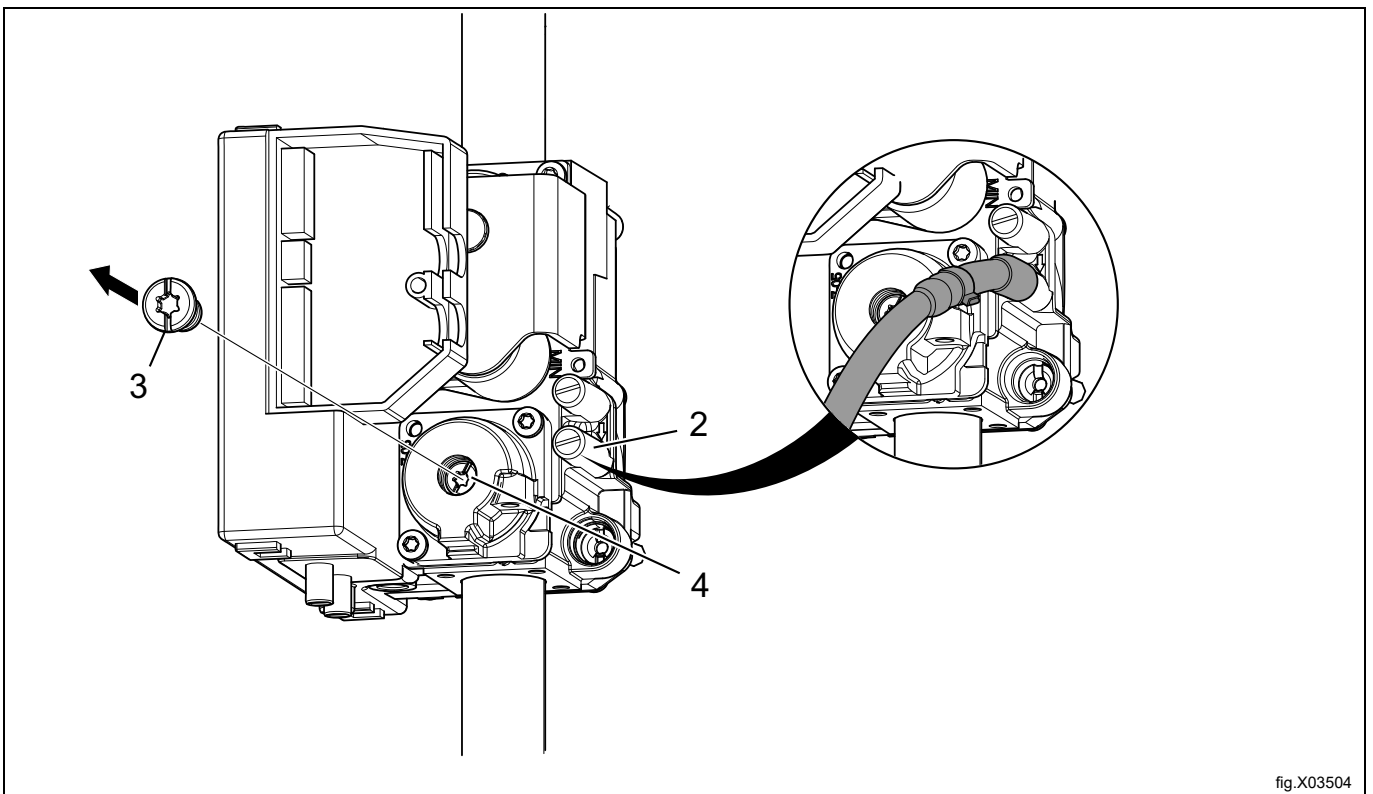

- Remount the cover screw (3).
- Remove the manometer and tighten the screw (2) when the adjustments are done.

### Note!

After connection all joints must be checked. There must not be any leaks.

## 6.5 Converting instructions

- Disconnect the power to the machine.
- Demount the back panel.
- Demount the air restriction plate (1).
- Demount the nozzle (2) and mount the new supplied nozzle.
- Re-mount the air restriction plate.

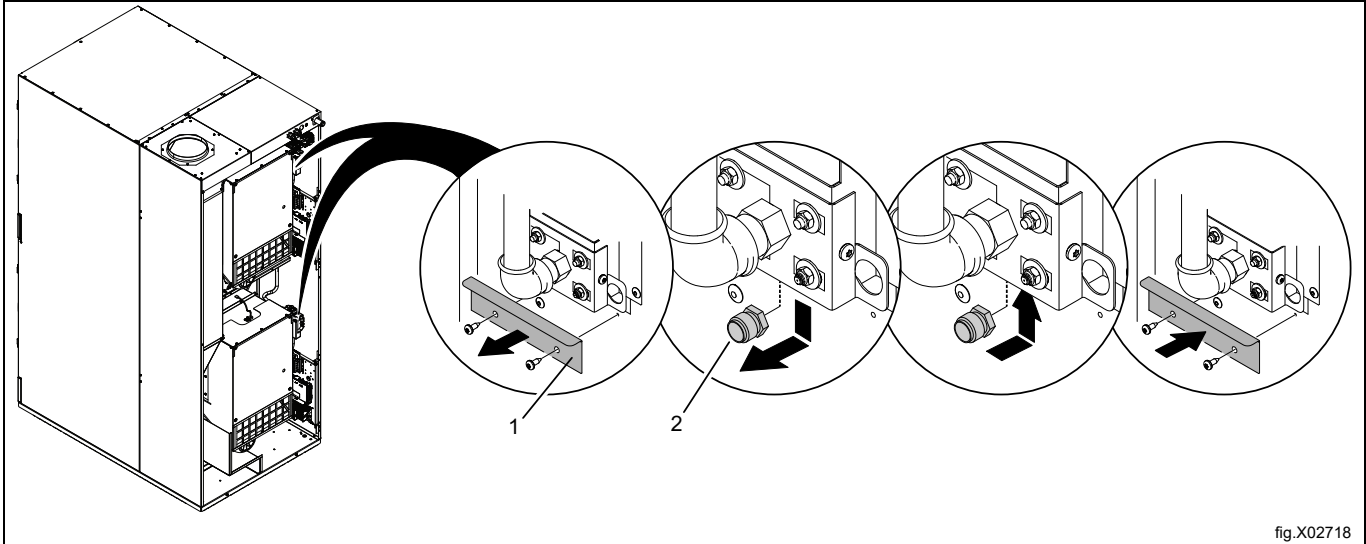

fig.X02718

- Loosen the measuring branch screw (2) 1/4 turn; connect a manometer to the measuring branch.
- Connect the power to the machine and select a program with heat.
- Start the machine.
- Set the correct nozzle pressure according to the table on setting screw (4) under the cover screw (3).

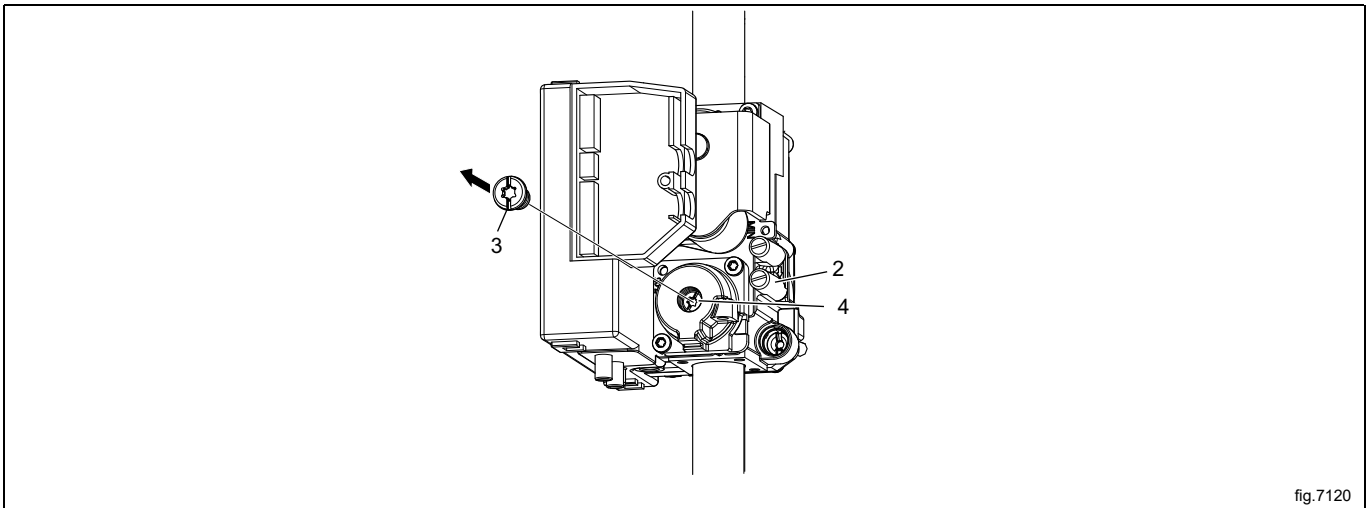

fig.7120

- Check that the gas flame burns evenly.
- Mount the cover screw (3).
- Tighten the screw (2) when the adjustments are done.
- Remount the back panel.

### Note!

After connection all joints must be checked. There must not be any leaks.

### 6.6 Data label

When the machine is to be converted to another gas type, the data label at the rear of the machine must be updated in order for the data to be correct.

Place the data label enclosed in the conversion kit on top of the data label as shown below. If there are more than one data label, select the label with the correct country code and gas type.

WXXXXX  
 Product no.: 9868XXXXXX  
 Serial no.: 09XXX / 99XXXXX  
 OC: 09XXXXXX Date: 10XX Wiring diag: 432XXXXXXX  
 Program: 432XXXXXX,5XXX  
 Type: WN3...WN3XXXX

WXXXXX  
 Product no.: 9868XXXXXX  
 Serial no.: 09XXX / 99XXXXX  
 OC number: 09XXXXXX Date(YMM): 10XX  
 Capacity: X kg  
 Type/Model: WN3...WN3XXXX  
 Voltage: 380 – 400V 3N ~ 50Hz  
 Rated Input: 1,6kW

10A

INPUT : A BTU/H CONTROL NO B  
 PROPANE GAS : 2568 BTU/CUFT  
 INLET PRESSURE REC: 11 " WC  
 MAX: 13 " WC  
 MIN: 8 " WC  
 ORFICE MM: D (0-200 FT ALTITUDE)  
 MANIFOLD PRESSURE: 11 " WC  
 CLOTHES DRYER VOL: II

INPUT : A BTU/H CONTROL NO B  
 NATURAL GAS : 1014 BTU/CUFT  
 INLET PRESSURE REC: 7 " WC  
 MAX: 10.5 " WC  
 MIN: 3.5 " WC  
 ORFICE MM: D (0-200 FT ALTITUDE)  
 MANIFOLD PRESSURE: C " WC  
 CLOTHES DRYER VOL: II

**For safety reasons use only genuine spare parts.**

**Made in Sweden**  
 Electrolux Professional AB  
 341 80 Ljungby, Sweden

WXXXXX  
 Product no.: 9868XXXXXX  
 Serial no.: 09XXX / 99XXXXX  
 OC: 09XXXXXX Date: 10XX Wiring diag: 432XXXXXXX  
 Program: 432XXXXXX,5XXX  
 Type: WN3...WN3XXXX

fig.7110B

## 7 Electrical connection

### 7.1 Electrical installation



The electrical installation may only be carried out by qualified personnel.



Machines with frequency-controlled motors can be incompatible with certain types of earth leakage circuit breaker. It is important to know that the machines are designed to provide a high level of personal safety, which is why items of external equipment such as earth leakage circuit breakers are not necessary but is recommended. If you still want to connect your machine across an earth leakage circuit breaker, please remember the following:

- contact a skilled, authorised installation company to ensure that the appropriate type of breaker is chosen and that the dimensioning is correct
- for maximum reliability, connect only one machine per earth leakage circuit breaker
- it is important that the earth wire is properly connected.

In instances where the machine is not equipped with an omni-polar switch, one must be installed beforehand.

In accordance with the wiring rules: mount a multi-pole switch prior to the machine to facilitate installation and service operations.

The connecting cable shall hang in a gentle curve.

### 7.2 Single-phase connection

Demount the upper rear cover panel. Connect the earth and other wires as shown.

1NAC	<p>Top</p>	<p>Bottom</p>
1NAC	<p>Top</p>	<p>Bottom</p>
1NAC	<p>Top</p>	<p>Bottom</p>

When the installation is completed remount the cover panel and check:

- That the drum is empty.
- That the machine operates by connecting the power to the machine and start a program with heat.

## 7.3 Three-phase connection

Demount the upper rear cover panel. Connect the earth and other wires as shown.

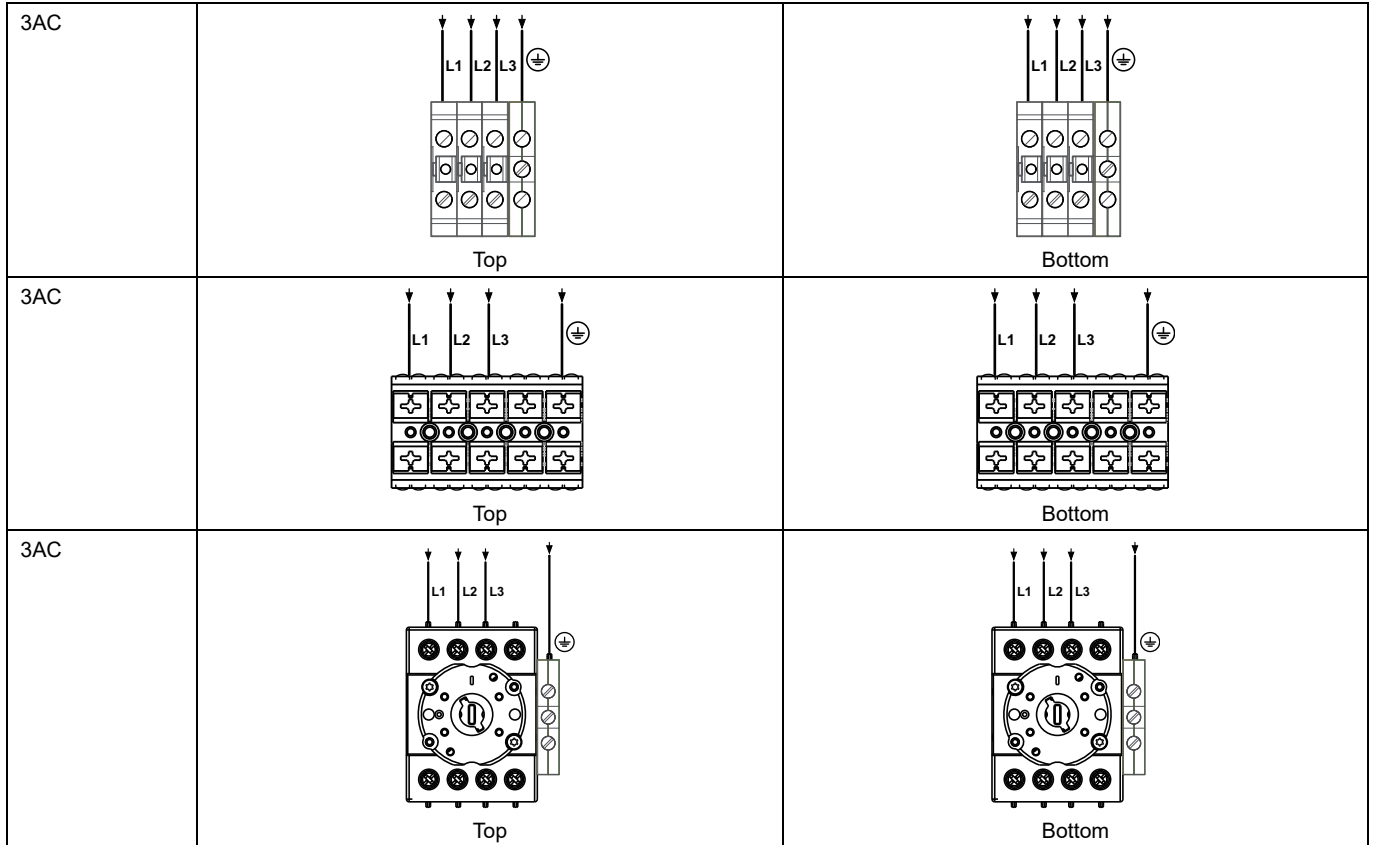

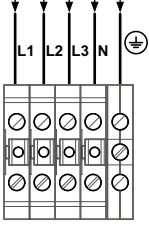
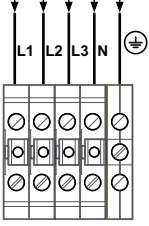
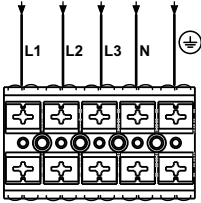
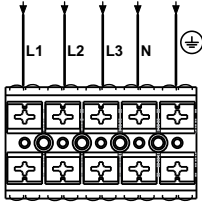
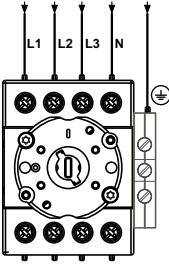
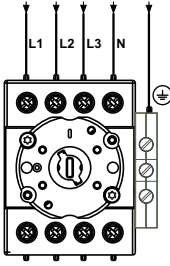
3NAC	 <p style="text-align: center;">Top</p>	 <p style="text-align: center;">Bottom</p>
3NAC	 <p style="text-align: center;">Top</p>	 <p style="text-align: center;">Bottom</p>
3NAC	 <p style="text-align: center;">Top</p>	 <p style="text-align: center;">Bottom</p>

When the installation is completed remount the cover panel and check:

- That the drum is empty.
- That the machine operates by connecting the power to the machine and start a program with heat.

**7.4 Electrical connections**

<b>Electrical connections</b>					
Heating alternative	Main voltage	Hz	Heating power kW	Total power kW	Recommended fuse ITCB
Gas heated	120V 1~	60	1	1.55	20
	208–240V 1~	60	1	1.55	15

1. Total power and recommended fuse does not depend on the heating power in those cases.

## 8 At first power up

When the installation is complete and the power is connected for the first time you will be forced to make the following settings. When one setting is ready you will automatically enter the next one. Follow the instructions on the display.

- Select language
- Set time and date
- Activate/deactivate the service alarm

### 8.1 Select language

Select language from the list on the display. Scroll with the up- and down arrows.

This will be the language that all display messages, program names etc will be presented in.

### 8.2 Set time and date

Select **YES** and press **▶||** to get to the **TIME/DATE** menu.

Activate the **SET TIME** menu and set the correct time.

Save the settings.

Activate the **SET DATE** menu and set the correct date. Start by setting the year.

- Set the year. Exit to continue with a long press on **▶||**.
- Set the month. Exit to continue with a long press on **▶||**.
- Set the day. Exit with a long press on **▶||** and then save with a long press on **▶||**.

Exit the menu when ready.

### 8.3 Activate/Deactivate the service alarm

Set if the machine shall give a service alarm or not with **YES** or **NO**.

Exit and save the settings.

## 9 Function check



May only be carried out by qualified personnel.



A function check must be made when the installation is finished and before the machine can be ready to be used. Whenever a repair has been made, a function check must be performed before the machine can be used again.

### Check the automatic stop of the machine

- Start the machine.
- Check if the micro switches are working properly:  
The machine must stop if the door or filter door is opened.

### Check the direction of rotation (only on machines with 3-phase power supply, marine installation)

Demount the rear panel and start a program. Check that the direction of the fan wheel is correct.

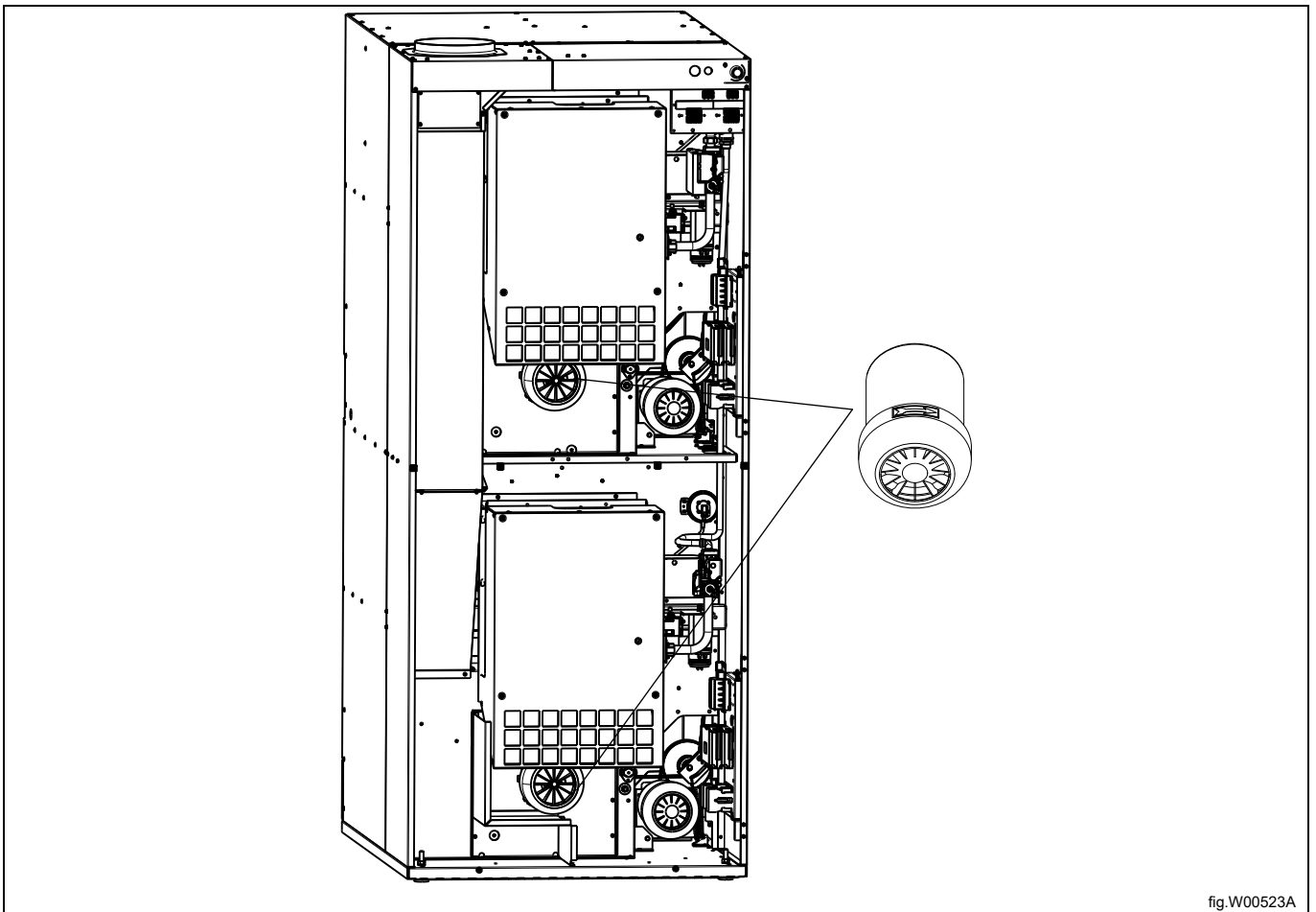

fig.W00523A

If the direction is wrong, swap two of the three phases to the left on the connection terminal.

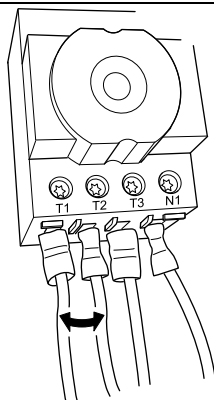

fig.7119

**Check the heat**

- Let the machine work for five minutes on a program with heat.
- Check that the heating is working by opening the door and feel if there is heat in the drum.

**Ready to use**

If all tests are OK the machine is now ready to be used.

If some of the tests failed, or deficiencies or errors are detected, please contact your local service organisation or dealer.

## 10 Disposal information

### 10.1 Appliance recyclability and disposal

#### 10.1.1 Recyclability

Our appliances are manufactured using a significant percentage of recyclable metals (such as stainless steel, iron, aluminium, galvanized sheet, copper, etc.), which can be recovered through the local recycling systems, in compliance with the regulations in force in the country of use.

National regulations regarding waste disposal may vary. Disposal of the appliance must therefore be carried out in accordance with the applicable legislation and the directives issued by the competent authorities in the country where the appliance is decommissioned.

The components of the appliance must be separated and disposed of in accordance with their material composition (e.g. metals, oils, greases, plastics, rubber, refrigerant gases, insulating boards and other insulating material, glass wool, LEDs, etc.) and in full compliance with applicable local and international waste management regulations.

Compressors may contain oils and refrigerants fluids - are special waste and has to be recycled on local bases regulations.

#### 10.1.2 Procedure regarding appliance disposal and component / material recovery

This product should not simply be disposed of in the environment at the end of its life cycle; it is imperative instead either to dispose of it in accordance with local environmental regulations, or, preferably, to deliver it whole to an authorized recycling center.

All removed components, including doors and other structural parts, must be delivered together with the appliance to an authorized recycling or dismantling facility.

The dismantling/recycling center will apply state of the art technologies and methods available to them to effectively disassemble the products for best recyclability.

Note that printed circuit boards, electrical motors or other components identified in European Union legislation to be of high critical raw materials recovery potential need to be addressed specifically.

In case of doubts or questions, always refer to your reference customer care service.

Before disposing of the appliance, carefully inspect its physical condition and preservation state, checking for potential leaks of liquids or gases, as well as for broken parts that may pose hazards during handling and subsequent dismantling.



The symbol on the product indicates that this product should not be treated as domestic waste, but must be correctly disposed of in order to prevent any negative consequences for the environment and human health. For further information on the recycling of this product, contact the local dealer or agent, the customer care service or the local body responsible for waste disposal.



#### Note!

**When dismantling the appliance, any marking, this manual and other documents concerning the appliance must be destroyed.**

### 10.2 Disposal of packing

The packing must be disposed of in compliance with the current regulations in the country where the appliance is used. All the packing materials are environmentally friendly.

They can be safely kept, recycled or burned in an appropriate waste incineration plant. Recyclable plastic parts are marked as following examples.

	Polyethylene: <ul style="list-style-type: none"> <li>• Outer wrapping</li> <li>• Instructions bag</li> </ul>
	Polypropylene: <ul style="list-style-type: none"> <li>• Straps</li> </ul>
	Polystyrene foam: <ul style="list-style-type: none"> <li>• Corner protectors</li> </ul>







[www.electroluxprofessional.com](http://www.electroluxprofessional.com)